



(19) **United States**

(12) **Patent Application Publication**
Kim

(10) **Pub. No.: US 2004/0056587 A1**

(43) **Pub. Date: Mar. 25, 2004**

(54) **DUAL-TYPE ORGANIC
ELECTROLUMINESCENCE DISPLAY AND
MANUFACTURING METHOD THEREOF**

Publication Classification

(51) **Int. Cl.⁷ H05B 33/00**

(52) **U.S. Cl. 313/500**

(75) **Inventor: Tae Seung Kim, Busan-city (KR)**

(57) **ABSTRACT**

Correspondence Address:
STAAS & HALSEY LLP
SUITE 700
1201 NEW YORK AVENUE, N.W.
WASHINGTON, DC 20005 (US)

A dual-type organic EL display including: a main organic EL device including a main substrate, strip-shaped main substrate scan lines, a main substrate organic light-emitting portion, and main substrate data lines formed on the main substrate; a sub organic EL device opposite to and facing the main organic EL device, including a sub substrate, strip-shaped sub substrate scan lines, a sub substrate organic light-emitting portion, and sub substrate data lines formed on the sub substrate; a sealant including a conductive spacer, sealing the main and sub substrates and hermetically sealing the main and sub substrate organic light-emitting portions in a state in which the main and sub organic EL devices face each other; and at least one flexible printed cable (FPC) formed on the main or sub substrate and connected to electrode lines of the main and/or sub substrates.

(73) **Assignee: Samsung NEC Mobile Display Co.,
Ltd., Ulsan-City (KR)**

(21) **Appl. No.: 10/665,044**

(22) **Filed: Sep. 22, 2003**

(30) **Foreign Application Priority Data**

Sep. 19, 2002 (KR) 2002-57389

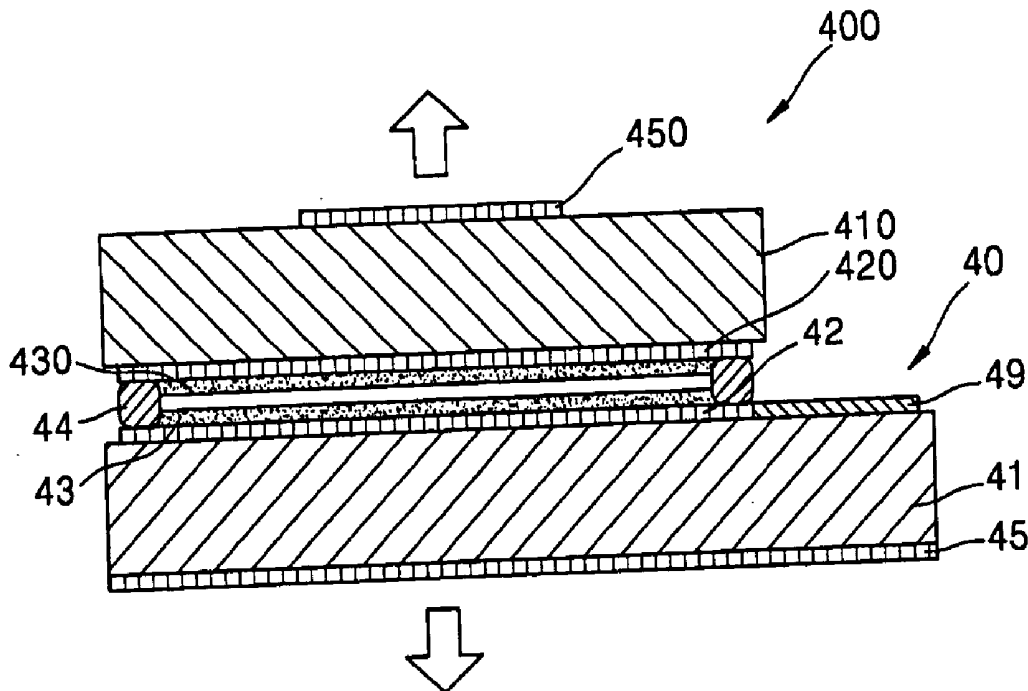

FIG. 1 (PRIOR ART)

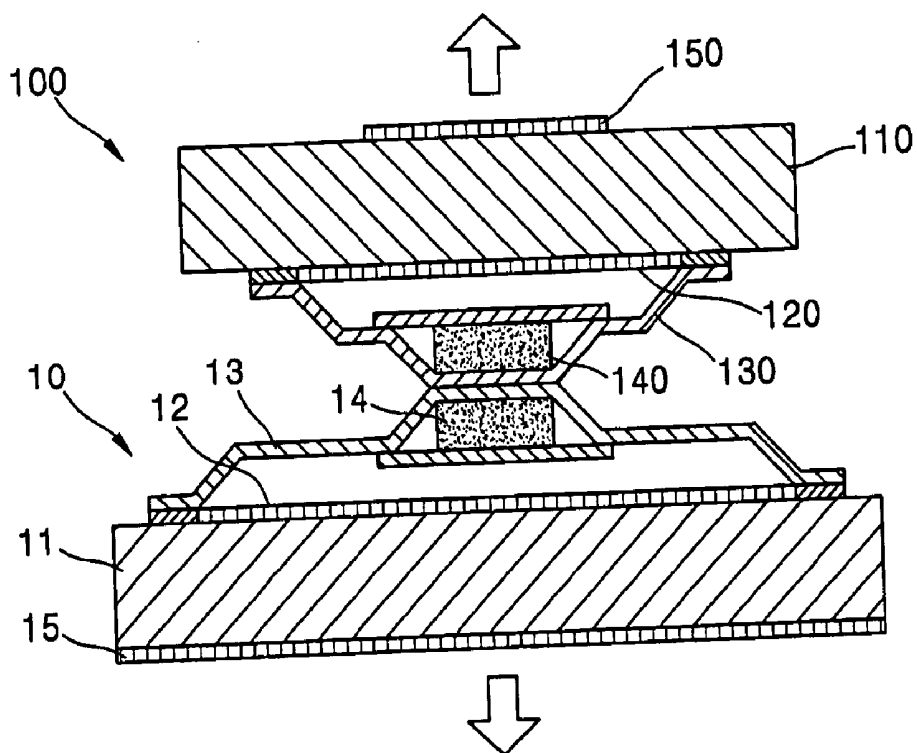

FIG. 2A (PRIOR ART)

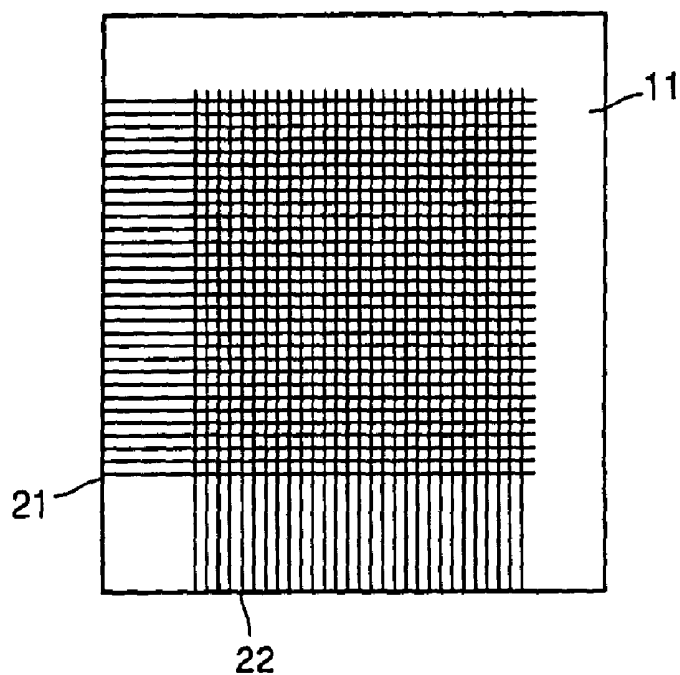

FIG. 2B (PRIOR ART)

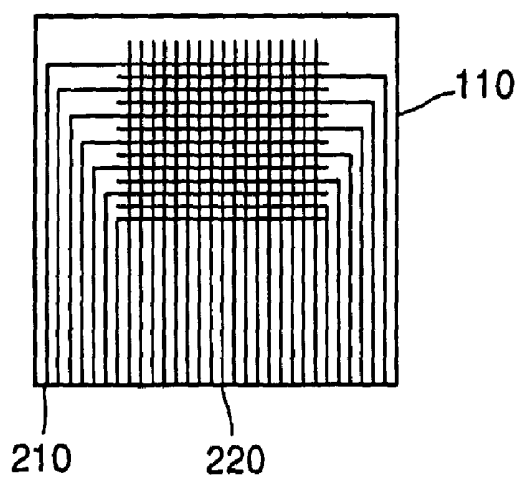

FIG. 3A (PRIOR ART)

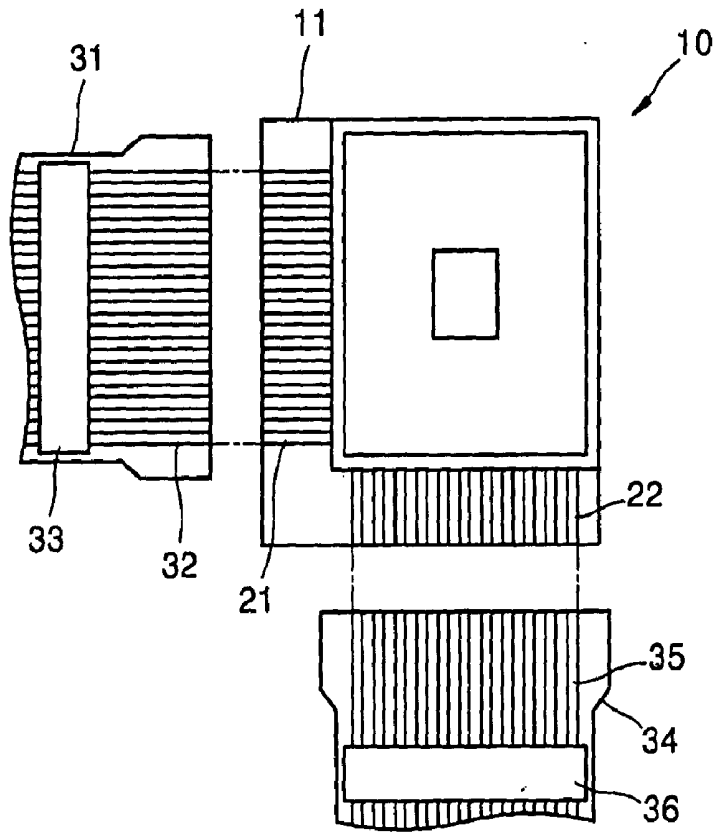

FIG. 3B (PRIOR ART)

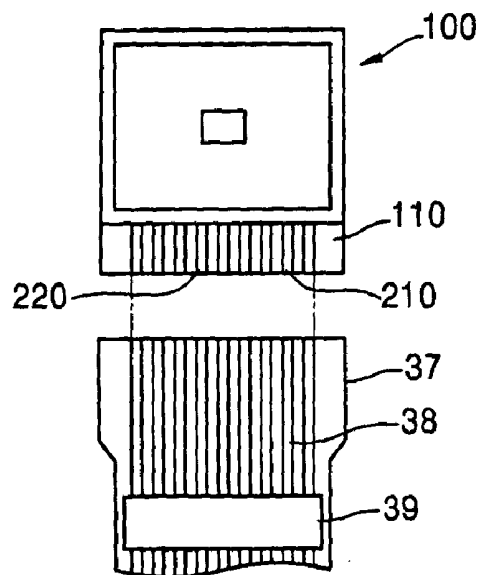

FIG. 4

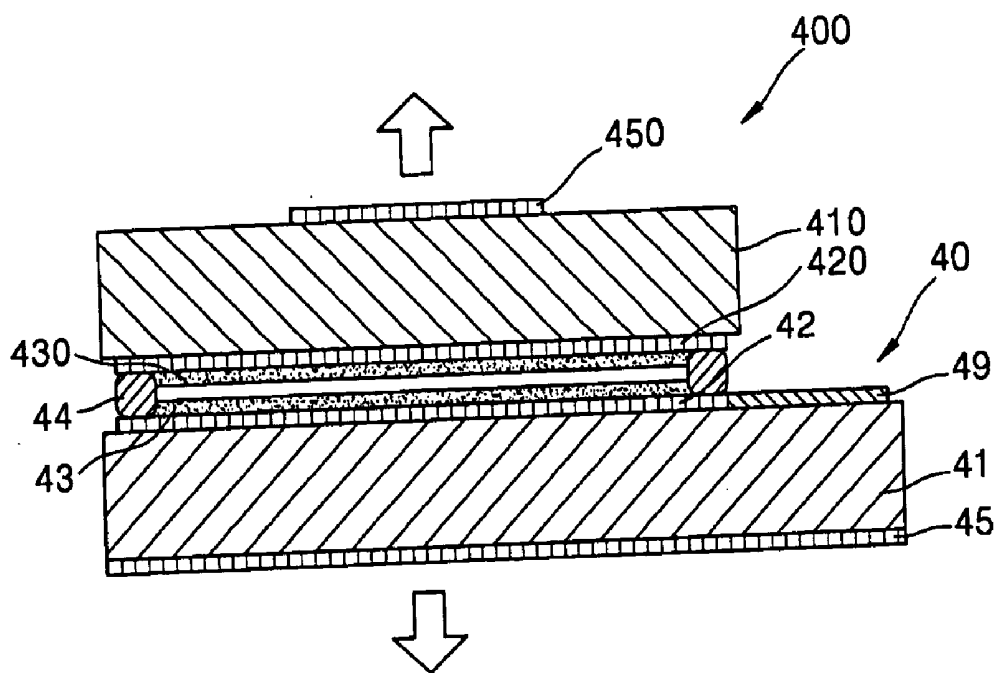

FIG. 5

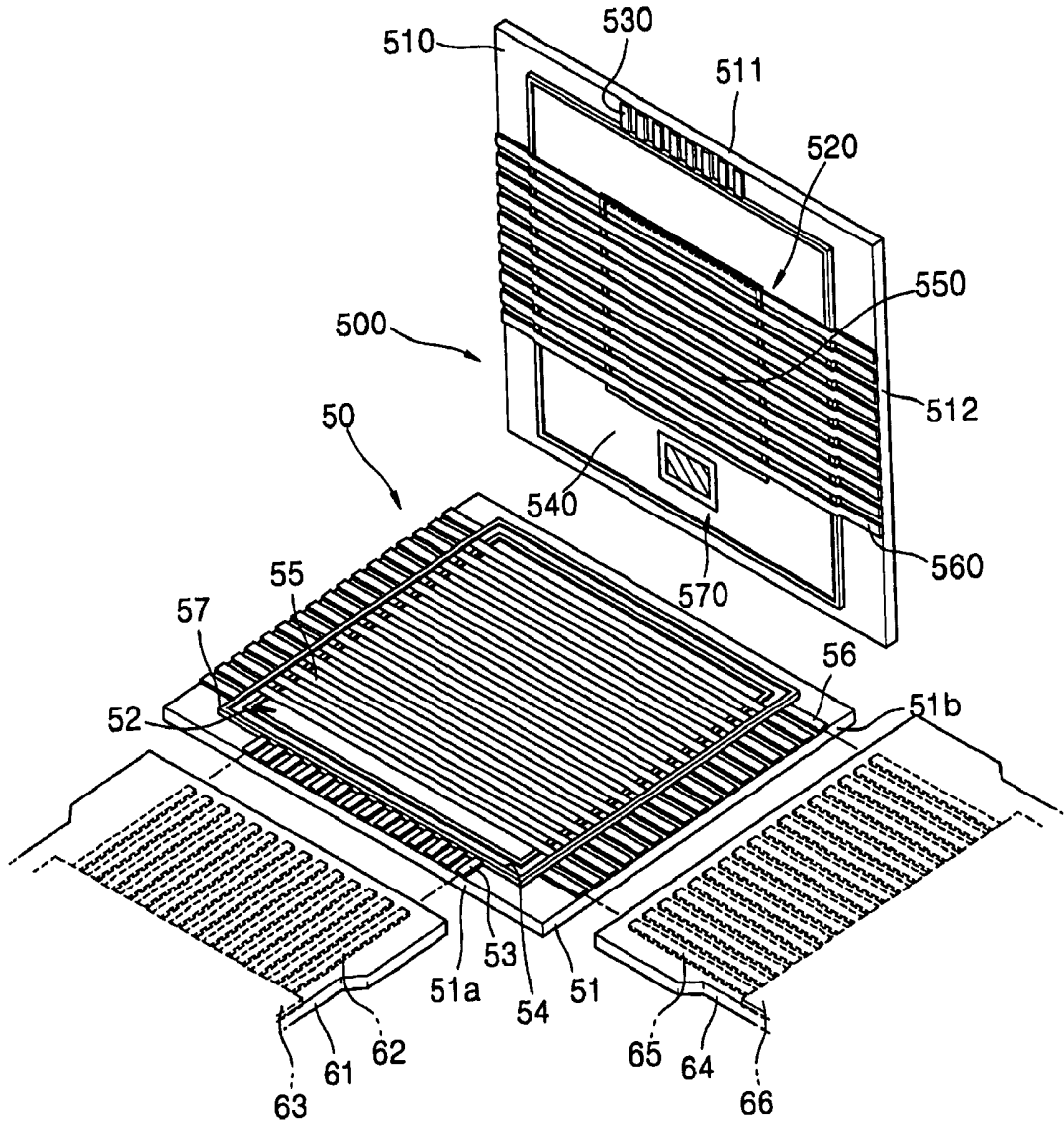

FIG. 6A

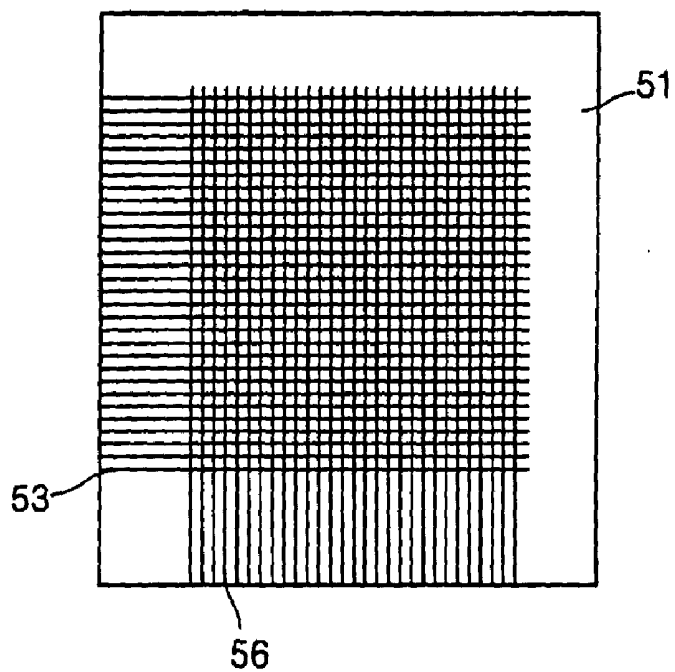

FIG. 6B

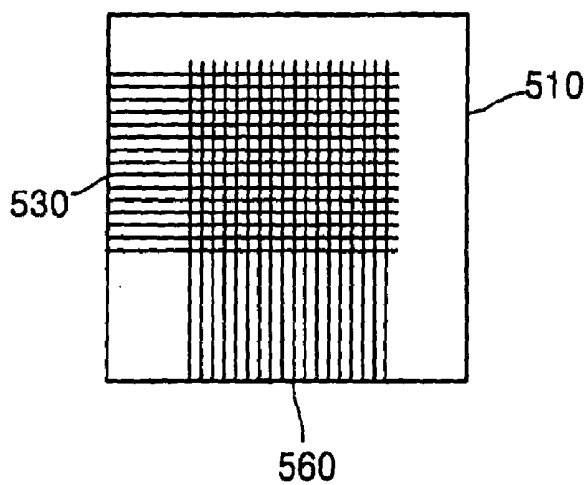

FIG. 7

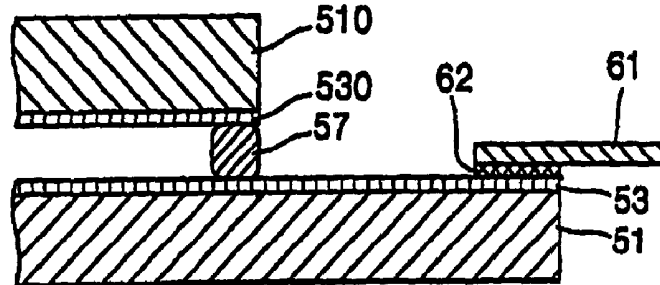

FIG. 8

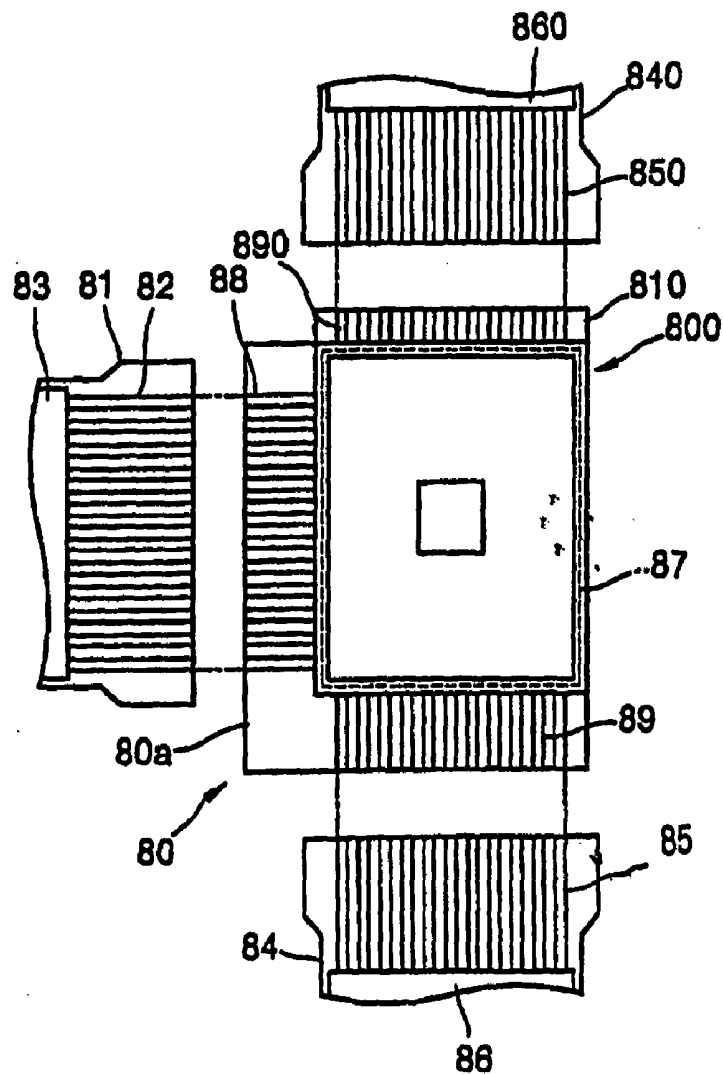

FIG. 9

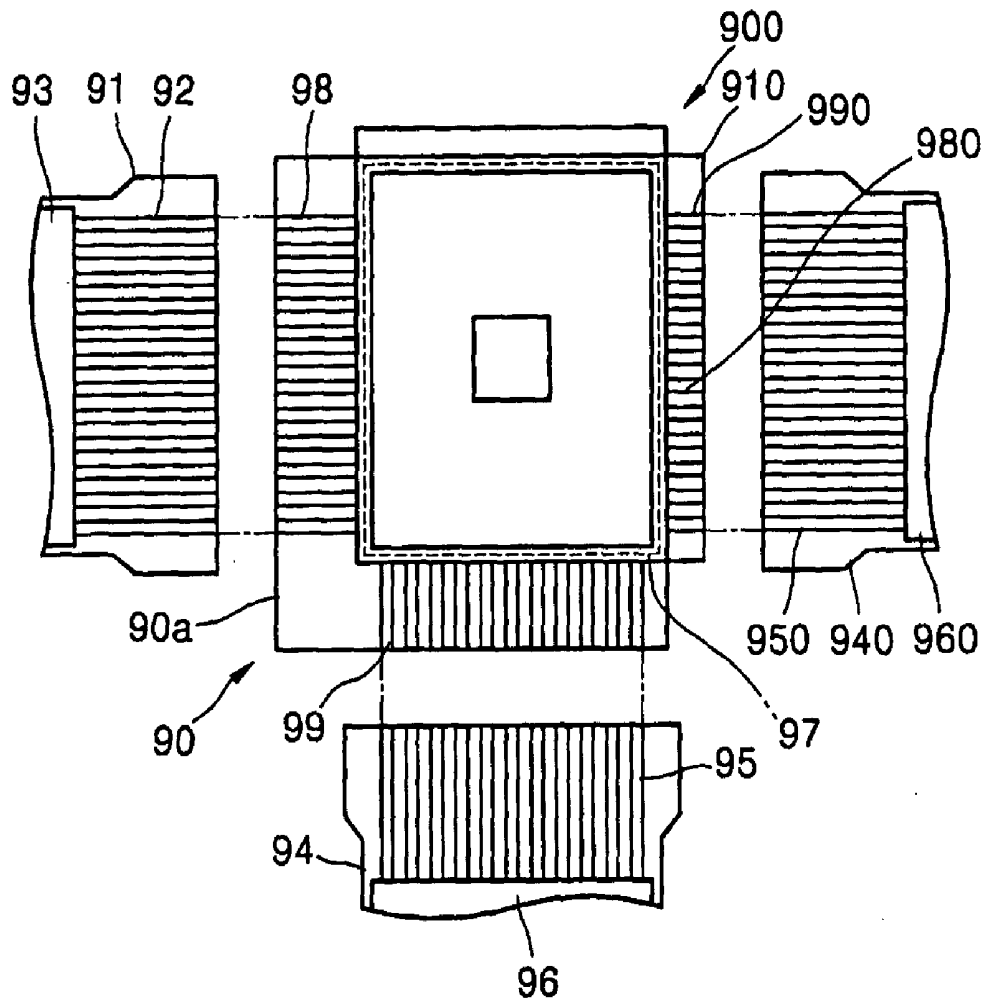

FIG. 10A

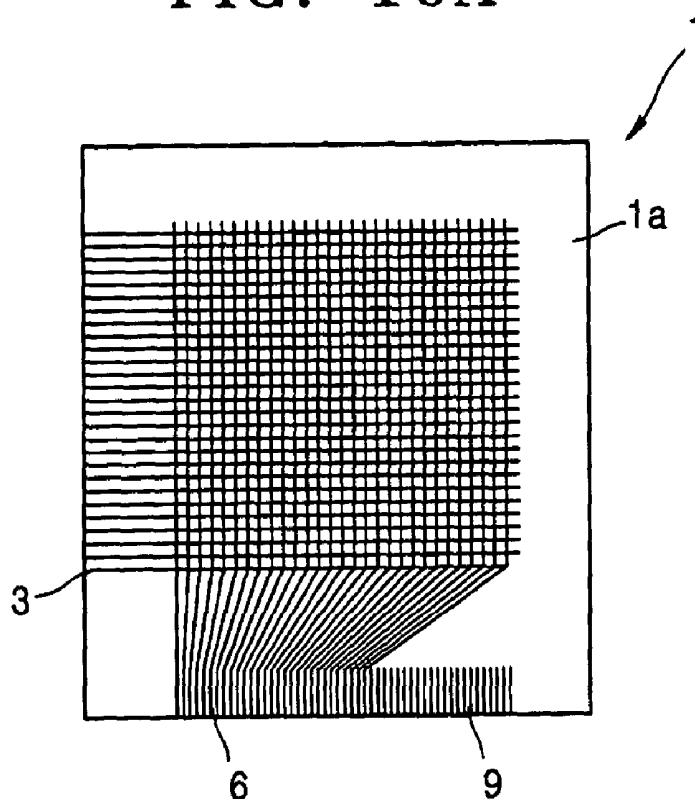
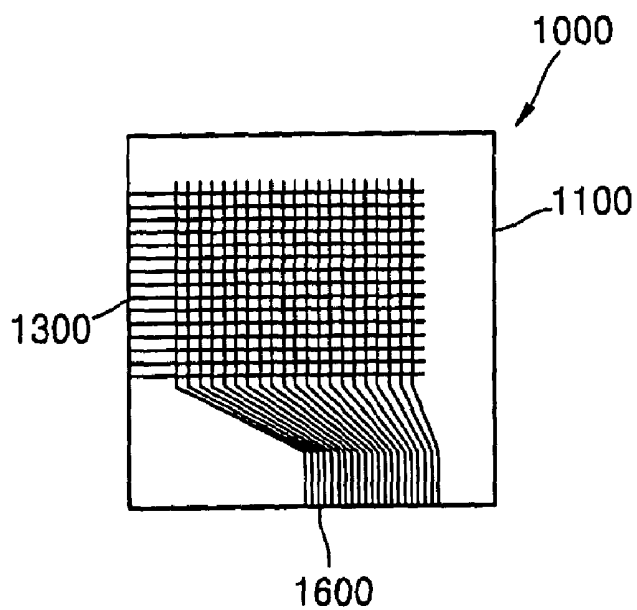

FIG. 10B



**DUAL-TYPE ORGANIC
ELECTROLUMINESCENCE DISPLAY AND
MANUFACTURING METHOD THEREOF**

CROSS-REFERENCE TO RELATED
APPLICATIONS

[0001] This application claims the benefit of Korean Patent Application No. 2002-57389, filed on Sep. 19, 2002, in the Korean Intellectual Property Office, the disclosure of which is incorporated herein reference.

BACKGROUND OF THE INVENTION

[0002] 1. Field of the Invention

[0003] The present invention relates to a dual-type organic electroluminescence (EL) display and a manufacturing method thereof, and, more particularly, to a dual-type organic electroluminescence display having an improved connection structure of a flexible printed cable electrically connected to terminals provided at main and sub organic EL displays and an improved driving method, and a manufacturing method thereof.

[0004] 2. Description of the Related Art

[0005] In general, organic EL displays are spontaneous light-emitting display devices which emit light through electrical excitation of fluorescent organic compounds, and provide various advantages including a low drive voltage and thin film formability. Also, organic EL displays are attracting much attention as next-generation display panels, since they provide a wide viewing angle, a fast response time, and so on.

[0006] An organic EL display operates as follows. When power is supplied, electrons migrate and current flows. At a cathode, electrons migrate to a light-emitting layer through an electron transport layer. At an anode, holes migrate to the light-emitting layer through a hole transport layer. The electrons and holes migrating to the light-emitting layer generate excitons having high energy. The excitons are deactivated to a ground state and thus light is emitted. Full color display can be achieved according to the kinds of an organic material forming the light-emitting layer.

[0007] Recently, users have desired dual type organic EL displays capable of simultaneously displaying two images in a folder type electronic device. The structure of the dual-type organic EL display is well known in Japanese Patent Application Laid-Open Nos. hei 10-255974, 2000-58260 and 2001-332392.

[0008] FIG. 1 shows a conventional dual type organic EL display.

[0009] Referring to FIG. 1, the dual-type organic EL display includes a main organic EL device 10 and a sub organic EL device 100.

[0010] The main organic EL device 10 includes a substrate 11, an organic light-emitting portion 12 formed on the substrate 11, a cap 13 protecting the organic light-emitting portion 12, a moisture absorbent 14 installed in the cap 13 and a polarizing plate 15 installed in front of the substrate 11.

[0011] The sub organic EL device 100 connected to the main organic EL device 10 has substantially the same structure as that of the main organic EL device 10, and

includes a substrate 110, an organic light-emitting portion 120, a cap 130, a moisture absorbent 140 and a polarizing plate 150.

[0012] In order to allow a user to selectively look at two displays in different directions indicated by arrows, the dual-type organic EL display has the sub organic EL device 100 connected to the rear surface of the main organic EL device 10.

[0013] For example, folder-type electronic devices can utilize external panel information directly displayed on a window without special manipulation just by employing a dual-type display device, and can utilize panel information displayed on another window by simple manipulation.

[0014] A process of manufacturing the dual-type organic EL display having the above-described configuration will now be briefly described.

[0015] A substrate 11 for the main organic EL device 10 is first provided. An organic light-emitting portion 12, including an anode, an insulator layer, an organic layer and a cathode, is then patterned on the substrate 11. A cap 13 for protecting the resultant structure is mounted, and a polarizing plate 15 is attached to the front surface of the substrate 11. In order to remove moisture generated in a sealed space, a moisture absorbent 14 is provided inside the cap 13.

[0016] Also, on a substrate 110 for the sub organic EL device 100, an organic light-emitting portion 120, a cap 130 provided with a moisture absorbent 140, and a polarizing plate 150 are mounted.

[0017] Next, the main and sub organic EL devices 10 and 100 are connected to each other in a state in which display portions are opposite to and face each other.

[0018] In the respective substrates 11 and 110 of the main and sub organic EL devices 10 and 100, electrode lines having a predetermined pattern are formed.

[0019] FIG. 2A shows electrode lines of the main organic EL device 10 shown in FIG. 1, and FIG. 2B shows electrode lines of the sub organic EL device 100 shown in FIG. 1.

[0020] Referring to FIGS. 2A and 2B, strip-shaped main substrate scan lines 21 and strip-shaped main substrate data lines 22 crossing the main substrate scan lines 21 are arranged on the substrate 11 for the main organic EL device 10, the respective lines spaced a predetermined distance from each other. The main substrate scan and data lines 21 and 22 are electrodes of the organic light-emitting portion 12. Strip-shaped sub substrate scan lines 210 and strip-shaped sub substrate data lines 220 parallel to the sub substrate scan lines 210 are arranged on the substrate 110 for the sub organic EL device 100, the respective lines spaced a predetermined distance from each other. The sub substrate scan and data lines 210 and 220 are grouped at a first side of the substrate 110.

[0021] Flexible printed cables (FPCs) are connected to the main and sub organic EL devices 10 and 100, having the respective electrode lines, applying external power, as shown in FIGS. 3A and 3B.

[0022] As shown in FIG. 3A, the main substrate scan lines 21 and the main substrate data lines 22 are arranged at two sides of the substrate for the main organic EL device 10. An FPC 31 for the main substrate scan lines 21 and an FPC 34

for the main substrate data lines **22** are connected to the main substrate scan and data lines **21** and **22**, respectively.

[0023] Interconnections **32** for the main substrate scan lines **21** and interconnections **35** for the main substrate data lines **22** are patterned in the FPCs **31** and **34**, respectively, and at least one drive chip **33**, **36**, driving both the main substrate scan and data lines **21** and **22**, is provided.

[0024] As shown in **FIG. 3B**, the sub substrate scan lines **210** and the sub substrate data lines **220** are drawn to a first side of the substrate **110** for the sub organic EL device **100**, and a sub substrate FPC **37** is connected to the sub substrate scan lines **210** and the sub substrate data lines **220**. Sub substrate interconnections **38** are patterned in the sub substrate FPC **37**, and a drive chip **39** for driving both the sub substrate scan and data lines **210** and **220** is disposed at the sub substrate FPC **37**.

[0025] The conventional dual-type organic EL display has the following problems.

[0026] First, the caps **13** and **130**, incorporating the respective moisture absorbents **14** and **140**, are installed at a connected portion of the main organic EL device **10** and the sub organic EL device **100**. The heights of the caps **13** and **130** are combined, resulting in an increase in the overall thickness of the dual-type organic EL display. Therefore, since there is a limitation in thinning, satisfactorily light-weight, miniaturized electronic devices cannot be obtained.

[0027] Second, since the FPCs **31** and **34** connected to the main substrate scan and data lines **21** and **22** of the main organic EL device **10**, the drive chips **33** and **36** mounted thereon, the sub substrate FPC **37** connected to the sub substrate scan and data lines **210** and **220** of the sub organic EL device **100**, and at least one drive chip **39** mounted on the FPC **37**, are all necessary, the design of the drive chips **33**, **36** and **39** is complicated, resulting in an increase in cost.

SUMMARY OF THE INVENTION

[0028] The present invention provides a dual-type organic electroluminescence (EL) display having an improved connection structure between scan and data lines thereof and a flexible printed cable electrically connected thereto, the dual-type organic EL display capable of driving images independently at two effective screens, and a manufacturing method thereof.

[0029] Additional aspects and/or advantages of the invention will be set forth in part in the description which follows and, in part, will be obvious from the description, or may be learned by practice of the invention.

[0030] In an aspect of the present invention, there is provided a dual-type organic electroluminescence (EL) display comprising a main organic EL device comprising a main substrate, strip-shaped main substrate scan lines, a main substrate organic light-emitting portion, and main substrate data lines formed on the main substrate, a sub organic EL device opposite to and facing the main organic EL device, comprising a sub substrate, strip-shaped sub substrate scan lines, a sub substrate organic light-emitting portion, and sub substrate data lines formed on the sub substrate, a sealant comprising a conductive spacer, sealing the main and sub substrates and hermetically sealing the main and sub substrate organic light-emitting portions in a

state in which the main and sub organic EL devices face each other, and at least one flexible printed cable (FPC) formed on the main or sub substrate and connected to electrode lines of the main and/or sub substrates.

[0031] In another aspect of the present invention, there is provided a dual-type organic electroluminescence (EL) display comprising a main organic EL device comprising a main substrate, strip-shaped main substrate scan lines, a main substrate organic light-emitting portion, and main substrate data lines formed on the main substrate, a sub organic EL device opposite to and facing the main organic EL device, comprising a sub substrate, strip-shaped sub substrate scan lines, a sub substrate organic light-emitting portion, and sub substrate data lines formed on the sub substrate, a sealant comprising a conductive spacer, sealing the main and sub substrates and hermetically sealing the main and sub substrate organic light-emitting portions in a state in which the main and sub organic EL devices face each other, floating electrode lines formed on the main or sub substrate and connected to electrode lines on the remaining main or sub substrate, and at least one flexible printed cable (FPC) connected to the main and/or sub substrate, wherein a plurality of the electrode lines on the main and sub substrates are electrically connected to each other by the conductive spacer.

[0032] In still another aspect of the present invention, there is provided a method of manufacturing a dual-type organic EL display comprising preparing a main organic EL device by forming main substrate scan lines, a main substrate insulating layer, a main substrate organic layer, and main substrate data lines crossing the main substrate scan lines on a transparent main substrate, preparing a sub organic EL device by forming sub substrate scan lines, a sub substrate insulating layer, a sub substrate organic layer, and sub substrate data lines crossing the sub substrate scan lines on a transparent sub substrate, aging the main and sub organic EL devices, sealing along the periphery of an effective display area to hermetically seal the main and sub organic EL devices so as not to be exposed to outside elements, wherein the sealant comprises a conductive spacer, and connecting flexible printed cables (FPCs) transmitting a drive signal to at least one of the main and sub substrate scan lines and/or at least one of the the main and sub substrate data lines electrically connected to each other by the sealant.

BRIEF DESCRIPTION OF THE DRAWINGS

[0033] These and/or other aspects and advantages of the invention will become apparent and more readily appreciated from the following description of the embodiments, taken in conjunction with the accompanying drawings of which:

[0034] **FIG. 1** is a cross-sectional view of a conventional dual-type organic EL display;

[0035] **FIG. 2A** is a schematic diagram of electrode lines of a main organic EL device shown in **FIG. 1**;

[0036] **FIG. 2B** is a schematic diagram of electrode lines of a sub organic EL device shown in **FIG. 1**;

[0037] **FIG. 3A** is a schematic diagram of the main organic EL device shown in **FIG. 1**;

[0038] FIG. 3B is a schematic diagram of the sub organic EL device shown in FIG. 1;

[0039] FIG. 4 is a cross-sectional view of a dual-type organic EL display according to an embodiment of the present invention;

[0040] FIG. 5 is a cross-sectional view of a dual-type organic EL display according to another embodiment of the present invention;

[0041] FIG. 6A is a schematic diagram of electrode lines of a main organic EL device shown in FIG. 5;

[0042] FIG. 6B is a schematic diagram of electrode lines of a sub organic EL device shown in FIG. 5;

[0043] FIG. 7 is a cross-sectional view of a conductive spacer shown in FIG. 5;

[0044] FIG. 8 is a cross-sectional view of a dual-type organic EL display according to still another embodiment of the present invention;

[0045] FIG. 9 is a cross-sectional view of a dual-type organic EL display according to yet another embodiment of the present invention;

[0046] FIG. 10A is a schematic diagram of electrode lines of a main organic EL device according to yet another embodiment of the present invention; and

[0047] FIG. 10B is a schematic diagram of electrode lines of a sub organic EL device according to the embodiment of FIG. 10A.

DETAILED DESCRIPTION OF THE PREFERRED EMBODIMENTS

[0048] Reference will now be made in detail to the embodiments of the present invention, examples of which are illustrated in the accompanying drawings, wherein like reference numerals refer to the like elements throughout. The embodiments are described below to explain the present invention by referring to the figures.

[0049] FIG. 4 is a cross-sectional view of a dual-type organic EL display according to an embodiment of the present invention.

[0050] Referring to FIG. 4, the dual-type organic EL display includes a main organic EL device 40 and a sub organic EL device 400 connected to the main organic EL device 40, so display images are projected on two displays as indicated by the arrows.

[0051] A transparent main substrate 41 is provided in the main organic EL device 40, and a main substrate organic light-emitting portion 42 is formed on the main substrate 41.

[0052] The main substrate organic light-emitting portion 42 includes main substrate scan lines as first electrode lines, a main substrate insulating layer formed to expose the main substrate scan lines, a main substrate organic layer crossing the main substrate insulating layer, and main substrate data lines as second electrode lines formed on the main substrate organic layer.

[0053] The main substrate organic light-emitting portion 42 is covered by a main substrate passivation layer 43, e.g., a transparent epoxy, in order to prevent external moisture

from infiltrating. A main polarizing plate 45 is attached to the front surface of the main substrate 41.

[0054] Also, a sub substrate 410 is provided in the sub organic EL device 400, and a sub substrate organic light-emitting portion 420 is formed on the sub substrate 410.

[0055] The sub substrate organic light-emitting portion 420 includes sub substrate scan lines as third electrode lines, a sub substrate insulating layer, a sub substrate organic layer, and sub substrate data lines as fourth electrode lines.

[0056] The sub substrate organic light-emitting portion 420 is covered by the sub substrate passivation layer 430, and a sub polarizing plate 450 is attached to the front surface of the sub substrate 410.

[0057] The sub substrate organic light-emitting portion 420 and the sub substrate passivation layer 430 formed on the sub substrate 410 are opposite to and face the main substrate organic light-emitting portion 42 and the main substrate passivation layer 43 formed on the main substrate 41. A moisture absorbent sheet may be additionally installed between the main and sub substrate passivation layers 43 and 430.

[0058] On the main substrate 41 are provided the main substrate organic light-emitting portion 42 and electrode lines 49 selectively electrically connected to the sub substrate organic light-emitting portion 420, and electrically connected to the main substrate organic light-emitting portion 42.

[0059] A sealant 44 is provided at a connected portion of the main and sub organic EL devices 40 and 400 on either substrate for hermetically sealing the area containing the light emitting portions 42 and 420. The sealant 44 is applied on the substrate along the periphery of an outer region of an effective display portion.

[0060] The sealant 44 may be formed on only one of the main and sub substrates 41 and 410, rather than on both, in view of simplicity of the manufacturing process.

[0061] Meanwhile, the sealant 44 includes a conductive spacer so that the main and sub substrate organic light-emitting portions 42 and 420 can be selectively electrified through the electrode lines 49, which will later be described in detail.

[0062] In the aforementioned dual-type organic EL display, the facing main and sub substrates 41 and 410 can be connected to each other without installation of a cap which may increase the overall thickness, thereby greatly reducing the thickness of the device. Also, the main and sub substrate organic light-emitting portions 42 and 420 are covered by the main and sub substrate passivation layers 43 and 430, respectively, thereby preventing the infiltration of external moisture.

[0063] FIG. 5 is a cross-sectional view of a dual-type organic EL display according to another embodiment of the present invention, FIG. 6A is a schematic diagram of electrode lines of a main organic EL device shown in FIG. 5, and FIG. 6B is a schematic diagram of electrode lines of a sub organic EL device shown in FIG. 5.

[0064] Referring to FIGS. 5, 6A and 6B, the dual-type organic EL display includes a main organic EL device 50

and a sub organic EL device **500** opposite to and facing the main organic EL device **50**, thereby allowing image display on two screens.

[0065] In the main organic EL device **50**, there is provided a main substrate **51** made of a transparent material for transmitting light, and a main substrate organic light-emitting portion **52** is formed on the main substrate **51**.

[0066] The main substrate organic light-emitting portion **52** includes strip-shaped main substrate scan lines **53** as first electrode lines, a main substrate insulating layer **54**, a main substrate organic layer **55**, and strip-shaped main substrate data lines **56** as second electrode lines. The main substrate scan lines are spaced a predetermined distance from each other and are formed on the main substrate **51**. The main substrate insulating layer **54** is formed on the plane of the main substrate **51** having the main substrate scan lines **53**, forming pixels. The main substrate organic layer **55** is formed so as to cross the main substrate scan lines **53**. The main substrate data lines **56** are spaced a predetermined distance from each other on the main substrate organic layer **55**. The main substrate scan and data lines **53** and **56** cross each other.

[0067] The sub organic EL device **500** also has a sub substrate **510** made of a transparent material. A sub substrate organic light-emitting portion **520** is formed on the sub substrate **510**. The sub substrate organic light-emitting portion **520** has substantially the same structure as that of the main substrate organic light-emitting portion **52**.

[0068] That is to say, the sub substrate organic light-emitting portion **520** includes sub substrate scan lines **530** as third electrode lines, a sub substrate insulating layer **540**, a sub substrate organic layer **550**, and sub substrate data lines **560** as fourth electrode lines, the sub substrate scan and data lines **530** and **560** crossing each other.

[0069] A sealant **57** for connecting rear surfaces of the main and sub organic EL devices **50** and **500** is coated along the peripheries of outer regions of effective display areas of the main and sub substrates **51** and **510** to prevent the main and sub substrate organic light-emitting portions **52** and **520** from being exposed to outside elements, thereby preventing the infiltration of external moisture. The sealant **57** includes a conductive spacer.

[0070] In order to prevent the main and sub substrate organic layers **55** and **550** of the main and sub substrate organic light-emitting portions **52** and **520** from being damaged due to the moisture infiltrating through the sealant **57**, a moisture absorbent **570** is provided at a sealed area defined by the sealant **57**. The moisture absorbent **570** is installed within a recess formed at an edge of the sub substrate organic light-emitting portion **520**. In order to prevent escape of the moisture absorbent **570**, a porous tape is attached thereto.

[0071] Here, the main substrate scan lines **53** are spaced a predetermined distance from each other along a first side **51a** of the main substrate **51**, and the main substrate data lines **56** are disposed along a second side **51b** of the main substrate **51**. The sub substrate scan lines **530** are disposed along a first side **511** of the sub substrate **510**, and the sub substrate data lines **560** are disposed along a second side **512** of the sub substrate **510**.

[0072] FPCs are connected to either the main or sub substrate **51** or **510**, applying external power to drive both the main organic EL device **50** and the sub organic EL device **500**.

[0073] In other words, an FPC **61** for single substrate scan lines and an FPC **64** for single substrate data lines, connected to the main substrate scan and data lines **53** and **56**, respectively, are provided on the main substrate **51**. The FPC **61** can also be connected to the sub substrate scan lines **530**. Also, the FPC **64** can be electrically connected to the sub substrate data lines **560**. Interconnections **62** for scan lines and interconnections **65** for data lines are patterned in the FPCs **61** and **64**, and at least one drive chip **63**, **66**, each connected to the FPC **61**, **64**, is provided to the interconnections **62** and **65**.

[0074] Here, the sealant **57**, coated along peripheries of the effective display areas of the main and sub organic EL devices **50** and **500**, includes a conductive spacer. The sealant **57**, including the conductive spacer, is coated between the main substrate scan lines **53** formed on the main substrate **51** and the sub substrate scan lines **530** formed on the sub substrate **510**, and electrically connects the main and sub scan lines **53** and **530**, as shown in FIG. 7. The sealant **57** is also coated between the main substrate data lines **56** and the sub substrate data lines **560**.

[0075] The conductive spacer included in the sealant **57** is preferably formed of an anisotropic conductive material that produces conductivity vertically, but maintains an insulating property horizontally.

[0076] Accordingly, as shown in FIG. 5, the main and sub substrate scan lines **53** and **530** are spatially separated from each other, and when power is applied, current flows in both the main and sub substrate scan lines **53** and **530** through the FPC **61** for single substrate scan lines. The main and sub substrate data lines **56** and **560** are also spatially separated from each other.

[0077] As a result, the main organic EL device **50**, and the sub organic EL device **500** connected to the main organic EL device **50** at rear surfaces thereof, can be driven by the FPC **61** for single substrate scan lines, and by the FPC **64** for single substrate data lines.

[0078] Here, the interconnections **62** patterned on the scan lines of FPC **61** are designed so as to correspond to and be connected to the main and sub substrate scan lines **53** and **530**. Also, the interconnections **65** patterned on the data lines of FPC **64** are designed so as to correspond to and be connected to the main and sub substrate data lines **56** and **560**.

[0079] In the aforementioned dual-type organic EL display, the sealant **57** includes a conductive spacer interposed between the main and sub substrate scan lines **53** and **530** and between the main and sub substrate data lines **56** and **560**. Thus, the main and sub substrate scan lines **53** and **530** are spatially separated from each other, and so are the main and sub substrate data lines **56** and **560**.

[0080] Thus, when power is applied to the FPCs **61** and **64** for single substrate scan lines and single substrate data lines, drawn out from the main substrate **51**, in the case where the cover of the electronic device is closed, an image from the sub organic EL device **500** is driven. In the case where the

cover of the electronic device is opened, an image from the main organic EL device **50** is driven. Here, current flows in both the main and sub organic EL devices **50** and **500**.

[0081] A manufacturing method of the dual-type organic EL display will now be described.

[0082] First, the main substrate **51** of the main organic EL device **50** is provided. The main substrate **51** is preferably formed of a transparent material, e.g., glass. Strip-shaped main substrate scan lines **53** having a predetermined pattern are formed on the main substrate **51**. The main substrate scan lines **53** are formed from a transparent conductive film, for example, an ITO film, through exposure, development, and etching using a photo mask having a pattern corresponding to that of the main substrate scan lines **53**.

[0083] Next, the main substrate insulating layer **54** is formed on the main substrate **51** having the main substrate scan lines **53**. The main substrate insulating layer **54** may be formed by a plurality of strips perpendicular to the main substrate scan lines **53** by photolithography. Otherwise, the main substrate insulating layer **54** may be formed over the entire surface of the main substrate **51** except a portion exposed to the first side **51a** of the main substrate **51** so that the main substrate scan lines **53** for forming pixels are exposed in a predetermined pattern.

[0084] After forming the main substrate insulating layer **54**, the main substrate organic layer **55** is formed on the resultant structure having the main substrate **51**, the main substrate scan lines **53**, and the main substrate insulating layer **54**. When forming the main substrate organic layer **55**, a hole transport layer, a light-emitting layer, and an electron transport layer are formed.

[0085] After forming the main substrate organic layer **55**, strip-shaped main substrate data lines **56** are formed on the main substrate organic layer **55** in a direction perpendicular to the main substrate scan lines **53**. The main substrate data lines **56** are preferably formed by depositing a highly conductive, metallic material, for example, aluminum, silver, or silver alloy.

[0086] While manufacturing the main organic EL device **50**, the sub organic EL device **500** is manufactured in the same manner.

[0087] If the main organic EL device **50** and the sub organic EL device **500** are manufactured in such a manner, the respective devices **50** and **500** are aged. After aging, peripheries of the effective display areas of the main substrate **51** of the main organic EL device **50** and the sub substrate **510** of the sub organic EL device **500** are sealed by the sealant **57**, thereby preventing the main substrate organic light-emitting portion **52** and the sub substrate organic light-emitting portion **520** from being exposed to outside elements.

[0088] Since a conductive spacer is included within the sealant **57**, the main and sub substrate scan lines **53** and **530** are electrically connected to each other by the sealant **57**. Also, the main and sub substrate data lines **56** and **560** are electrically connected to each other by the sealant **57**.

[0089] Prior to sealing of the sealant **57**, a recess is formed at a first side of the sub substrate **511** and is filled with the moisture absorbent **570**, which is secured to the sub substrate **511** using a porous tape.

[0090] In the completed dual-type organic EL display, the FPC **61** for single substrate scan lines is connected to the main and sub substrate scan lines **53** and **530** drawn out to the first side **51a** of the main substrate **51** and electrically connected by the sealant **57**. Also, the FPC **64** for single substrate data lines is connected to the main and sub substrate data lines **56** and **560** drawn out to the second side **51b** of the main substrate **51** and electrically connected by the sealant **57**.

[0091] Accordingly, the main and sub organic EL devices **50** and **500** can be simultaneously driven by the FPCs **61** and **64** connected to one of the main and sub substrates (here, the main substrate **51**).

[0092] FIG. 8 is a cross-sectional view of a dual-type organic EL display according to still another embodiment of the present invention.

[0093] Referring to FIG. 8, the dual-type organic EL display includes a main organic EL device **80** and a sub organic EL device **800** opposite to and facing the main organic EL device **80**.

[0094] Main substrate scan lines **88** and main substrate data lines **89** are formed on a main substrate **80a** of the main organic EL device **80** so as to cross each other. A sub organic EL device **800** is connected to the surface of a main substrate **80a** having a main substrate organic light-emitting portion. Sub substrate scan lines and sub substrate data lines **890** are formed on a sub substrate **810** of the sub organic EL device **800** so as to cross each other.

[0095] Here, main substrate scan lines **88** of the main substrate **80a** and sub substrate scan lines patterned on the interior surface of the sub substrate **810** are electrically connected to each other by a sealant **87** coated on the periphery of an effective display area. The sealant **87** includes a conductive spacer made of an anisotropic conductive material. Such an anisotropic spacer has conductivity vertically only, and has an insulating property horizontally.

[0096] Accordingly, the main substrate scan lines **88** of the main substrate **80a** and the sub substrate scan lines of the sub substrate **810** are spatially separated from each other by the sealant **87**. An FPC **81** for main substrate scan lines, applying external power to drive both the main organic EL device **80** and the sub organic EL device **800**, is provided at either a main substrate or a sub substrate. The FPC **81** is provided at the main substrate **80a** in this embodiment. Interconnections **82** for scan lines are patterned on the FPC **81**, and a drive chip **83** connected to the interconnections **82** is disposed thereat. The drive chip **83** is shared by the main substrate scan lines and the sub substrate scan lines, and the same scan signal is applied thereto.

[0097] Also, an FPC **84** is connected to the main substrate data lines **89** of the main substrate **80a**. Interconnections **85** for the data lines are patterned on the FPC **84**, and a drive chip **86**, connected to the interconnections **85**, is disposed at the FPC **84**. The FPC **84** transmits an electrical signal from the drive chip **86** only to the main substrate data lines **89**.

[0098] An FPC **840** is connected to the sub substrate data lines **890** of the sub substrate **810**. Interconnections **850**, corresponding to the sub substrate data lines **890**, are patterned on the FPC **840**, and a drive chip **860** connected to the

interconnections **850** is disposed at the FPC **840**. Therefore, an electrical signal externally applied is transmitted only to the sub substrate data lines **890** via the drive chip **860**.

[0099] In the dual-type organic EL display according to the previously discussed embodiment of the present invention, as shown in **FIG. 5**, in a state in which the main substrate scan lines **53** and the sub substrate scan lines **530** are electrically connected to each other by the sealant **57**, the FPC **61** is connected to the main substrate scan lines **53** drawn out from the main substrate **51**, and the same signal is applied to the main substrate scan lines **53** and the sub substrate scan lines **530**. Also, in a state in which the main substrate data lines **56** and the sub substrate data lines **560** are electrically connected to each other by the sealant **57**, the FPC **64** is connected to the main substrate data lines **56**, and the same signal is applied to the main substrate data lines **56** and the sub substrate data lines **560**, thereby realizing the same image.

[0100] In the dual-type organic EL display according to the currently discussed embodiment of the present invention, as shown in **FIG. 8**, the main substrate scan lines **88** and the sub substrate scan lines are electrically connected to each other by the sealant **87**, and the FPC **81** for scan lines is connected to the main substrate scan lines **88** drawn out from the main substrate **80a**, so that the drive chip **83** can be shared by the main substrate scan lines **88** and the sub substrate scan lines and the same signal is applied thereto.

[0101] However, in this embodiment, the FPC **84** for single substrate data lines is connected to the main substrate data lines **89**, and the FPC **840** is connected to the sub substrate data lines **890**.

[0102] Accordingly, a signal for displaying an image from the sub organic EL device **800** when the cover of the dual-type organic EL display is closed, and for displaying an image from the main organic EL device **80** when the cover is opened, can be selectively applied to the dual-type organic EL display.

[0103] Since the main substrate data lines **89** formed on the main substrate **80a** and the sub substrate data lines **890** formed on the sub substrate **810** are connected to the FPCs **84** and **840** for the respective main and sub substrate data lines, they can be independently driven.

[0104] **FIG. 9** is a cross-sectional view of a dual-type organic EL display according to yet another embodiment of the present invention, in which different images are independently driven, like in **FIG. 8**.

[0105] Referring to **FIG. 9**, the dual-type organic EL display includes a main organic EL device **90** and a sub organic EL device **900** connected to the main organic EL device **90**.

[0106] The main organic EL device **90** has a main substrate organic light-emitting portion formed on a main substrate **90a**. Main substrate scan lines **98** and main substrate data lines **99**, perpendicular to the main substrate scan lines **98**, are drawn out from the main substrate organic light-emitting portion.

[0107] An FPC **91**, for main substrate scan lines, is electrically connected to the main substrate scan lines **98**. Interconnections **92** for the main substrate scan lines **98** are patterned in the FPC **91**, and a drive chip **93** for processing

electrical signals is connected to the interconnections **92**. An FPC **94** for main substrate data lines is connected to the main substrate data lines **99**. Interconnections **95** for main substrate data lines are patterned in the FPC **94**, and a drive chip **96** is connected to the interconnections **95**.

[0108] In the sub organic EL device **900**, a sub substrate organic light-emitting portion is formed on a sub substrate **910**. Sub substrate scan lines **980** and sub substrate data lines **990** are drawn out from the sub substrate organic light-emitting portion. The sub substrate scan and data lines **980** and **990** are grouped at a first side of the sub substrate **910**. Alternatively, the sub substrate scan and data lines **980** and **990** may be grouped at a second side of the sub substrate **910**, and are spaced a predetermined distance from the same side.

[0109] The sub substrate scan and data lines **980** and **990** are electrically connected to an FPC **940** for sub substrate electrode lines. The FPC **940** includes interconnections **950** for sub substrate electrode lines connected to the sub substrate scan and data lines **980** and **990**, and a drive chip **960** connected to the interconnections **950**. The sub substrate scan and data lines **980** and **990** are designed so as to be driven by the single drive chip **960**.

[0110] The main and sub organic EL devices **90** and **900** have a sealant **97** coated along the periphery of an effective display area for connecting the main and sub substrates **90a** and **910** to each other. The sealant **97** may include a conductive spacer. However, the conductive spacer is not necessarily included in the sealant **97** because the main and sub electrode lines are not electrically connected to each other in actual practice in this embodiment.

[0111] As described above, according to this embodiment of the present invention, like in the embodiment shown in **FIG. 8**, when the cover of the dual-type organic EL display is closed, an image from the sub organic EL device **900** is driven, and when the cover is opened, an image from the main organic EL device **90** is driven. That is, electrical signals are independently applied to the main and sub organic EL devices **90** and **900** of the dual-type organic EL display.

[0112] On the other hand, unlike in the embodiment shown in **FIG. 8**, the main and sub substrate data lines **99** and **990** can be independently driven, and the main and sub substrate scan lines **98** and **980** can also be independently driven.

[0113] **FIG. 10A** is a schematic diagram of electrode lines of a main organic EL device according to yet another embodiment of the present invention, and **FIG. 10B** is a schematic diagram of electrode lines of a sub organic EL device according to this embodiment of the present invention. Now, only electrode lines formed on substrates of main and sub organic EL devices **1** and **1000** will be described.

[0114] Referring to **FIGS. 10A and 10B**, strip-shaped main substrate scan lines **3** are spaced a predetermined distance from each other on a main substrate **1a** of a main organic EL device **1**, and main substrate data lines **6** are arranged in a direction perpendicular to the main substrate scan lines **3**.

[0115] Here, floating electrode lines **9** are spaced a predetermined distance apart from each other on the main

substrate **1a**. The floating electrode lines **9** are arranged on the main substrate **1a** so as to be disposed adjacent to the main substrate data lines **6**. The floating electrode lines **9** are not directly connected to, but are separately patterned from, the electrode lines on the main substrate **1a**.

[0116] To this end, the main substrate data lines **6**, spaced apart from each other in a narrow pitch, are grouped at a first side of the main substrate **1a**. In this manner, the main substrate data lines **6** are disposed on the main substrate **1a** in a narrow pitch and a free space of the main substrate **1a** is occupied by the floating electrode lines **9**.

[0117] On a sub substrate **1100** of the sub organic EL device **1000**, strip-shaped sub substrate scan lines **1300** are spaced a predetermined distance apart from each other. Sub substrate data lines **1600** are arranged in a direction perpendicular to the sub substrate scan lines **1300**. The sub scan and data lines **1300** and **1600** are formed in directions parallel to those of the main substrate scan and data lines **3** and **6**, respectively.

[0118] Here, the sub substrate data lines **1600** are grouped at a first side of the sub substrate **1100** to be electrically connected to the floating electrode lines **9**. That is to say, during patterning of electrodes, the sub substrate data lines **1600** are formed so as to correspond to the floating electrode lines **9**. In this manner, the floating electrode lines **9** are formed on the main substrate **1a** for the purpose of receiving external drive signals from the main substrate **1a**.

[0119] In the dual-type organic EL display having the above-described configuration, the sealant having a conductive spacer is coated along the periphery of an effective display area, so that the main substrate scan lines **3** and the sub substrate scan lines **1300** are selectively electrically connected, and an FPC for scanning may also be connected to the main or sub substrate scan lines. Also, a sealant including a conductive spacer may be coated between the floating electrode lines **9** and the sub substrate data lines **1600** for an electrical connection.

[0120] Therefore, the respective electrode lines are arranged on the main substrate **1a** and an FPC having a drive chip mounted thereon is connected to the electrode lines, thereby applying a signal for independently or simultaneously driving images.

[0121] As described above, the manufacturing method of the dual-type organic EL display according to the present invention has the following effects.

[0122] Since the main and sub organic EL devices have an effective display area sealed by a sealant including an anisotropic conductive spacer, the thicknesses thereof can be reduced. Also, main substrate scan and data lines, formed on a main substrate, and sub substrate scan and data lines, formed on a sub substrate, are selectively electrically connected to each other by the anisotropic conductive spacer, and therefore the number of drive chips transmitting electrical signals to the electrode lines can be greatly reduced. Accordingly, the thickness of an organic EL display can be remarkably reduced. Also, an improved driving method according to the present invention can reduce the cost.

[0123] Further, FPCs driving main and sub organic EL devices are attached to either a main or sub substrate using a sealant including a conductive spacer, thereby improving workability.

[0124] Although a few embodiments of the present invention have been shown and described, it would be appreciated by those skilled in the art that changes may be made in these embodiments without departing from the principles and spirit of the invention, the scope of which is defined in the claims and their equivalents.

What is claimed is:

1. A dual-type organic electroluminescence (EL) display comprising:

a main organic EL device comprising:

a main substrate,

strip-shaped main substrate scan lines,

a main substrate organic light-emitting portion, and

main substrate data lines formed on the main substrate;

a sub organic EL device opposite to and facing the main organic EL device, comprising:

a sub substrate,

strip-shaped sub substrate scan lines,

a sub substrate organic light-emitting portion, and

sub substrate data lines formed on the sub substrate;

a sealant comprising a conductive spacer, sealing the main and sub substrates and hermetically sealing the main and sub substrate organic light-emitting portions in a state in which the main and sub organic EL devices face each other; and

at least one flexible printed cable (FPC) formed on the main or sub substrate and connected to electrode lines of the main and/or sub substrates.

2. The dual-type organic EL display of claim 1, wherein the main substrate scan lines and the main substrate data lines are arranged on the main substrate, the sub substrate scan lines and the sub substrate data lines are arranged on the sub substrate, and the sealant is interposed between the main and sub substrate scan lines and between the main and sub substrate data lines.

3. The dual-type organic EL display of claim 2, wherein the main substrate scan lines are electrically connected to the sub substrate scan lines by the conductive spacer.

4. The dual-type organic EL display of claim 3, wherein the at least one FPC comprises an FPC for single substrate scan lines electrically connected to the main or sub substrate scan lines, and transmitting a drive signal to the main or sub substrate scan lines.

5. The dual-type organic EL display of claim 2, wherein the main substrate data lines are electrically connected to the sub substrate data lines by the conductive spacer.

6. The dual-type organic EL display of claim 5, wherein the at least one FPC comprises an FPC for single substrate data lines electrically connected to the main or sub substrate data lines, and transmitting a drive signal to the main or sub substrate data lines.

7. The dual-type organic EL display of claim 2, wherein the main substrate scan lines are electrically connected to the sub substrate scan lines by the conductive spacer.

8. The dual-type organic EL display of claim 7, wherein the at least one FPC comprises an FPC for single substrate

scan lines electrically connected to the main or sub substrate scan lines, and transmitting a drive signal to the main or sub substrate scan lines.

9. The dual-type organic EL display of claim 7, wherein the at least one FPC comprises an FPC for main substrate data lines electrically connected to the main substrate data lines, and transmitting a drive signal to the main substrate data lines.

10. The dual-type organic EL display of claim 7, wherein the at least one FPC comprises an FPC for sub substrate data lines electrically connected to the sub substrate data lines, and transmitting a drive signal to sub substrate data lines.

11. The dual-type organic EL display of claim 2, wherein the at least one FPC comprises FPCs for main substrate scan and data lines connected to the main substrate scan and data lines, respectively, and FPCs for sub substrate scan and data lines connected to the sub substrate scan and data lines, respectively.

12. The dual-type organic EL display of claim 1, wherein the main substrate scan lines are grouped at a first side of the main substrate and the main substrate data lines are arranged at a second side of the main substrate.

13. The dual-type organic EL display of claim 12, wherein the sub substrate scan lines are arranged on the sub substrate parallel to the main substrate scan lines, and the sub substrate data lines are arranged on the sub substrate parallel to the main substrate data lines.

14. The dual-type organic EL display of claim 1, wherein the conductive spacer comprises an anisotropic conductive material which is electrified vertically and insulated horizontally.

15. The dual-type organic EL display of claim 1, wherein the main substrate scan lines and the sub substrate scan lines are electrically connected to each other by the conductive spacer, and are connected to the FPC applying an identical scan line drive signal to the main substrate scan lines and the sub substrate scan lines.

16. The dual-type organic EL display of claim 1, wherein the main substrate data lines and the sub substrate data lines are electrically connected to each other by the conductive spacer, and are connected to the FPC applying an identical data line drive signal to the main substrate data lines and the sub substrate data lines.

17. A dual-type organic electroluminescence (EL) display comprising:

a main organic EL device comprising:

a main substrate,

strip-shaped main substrate scan lines,

a main substrate organic light-emitting portion, and

main substrate data lines formed on the main substrate;

a sub organic EL device opposite to and facing the main organic EL device, comprising:

a sub substrate,

strip-shaped sub substrate scan lines,

a sub substrate organic light-emitting portion, and

sub substrate data lines formed on the sub substrate;

a sealant comprising a conductive spacer, sealing the main and sub substrates and hermetically sealing the main

and sub substrate organic light-emitting portions in a state in which the main and sub organic EL devices face each other;

floating electrode lines formed on the main or sub substrate and connected to electrode lines on the remaining main or sub substrate; and

at least one flexible printed cable (FPC) connected to the main and/or sub substrate;

wherein a plurality of the electrode lines on the main and sub substrates are electrically connected to each other by the conductive spacer.

18. The dual-type organic EL display of claim 17, wherein the floating electrode lines are independently arranged at a first side of the main or sub substrate electrode lines.

19. The dual-type organic EL display of claim 18, wherein a pitch between each of the main or sub substrate electrode lines formed on the substrate with the floating electrode lines is smaller than that between each of the electrode lines formed on the substrate without the floating electrode lines.

20. The dual-type organic EL display of claim 17, wherein the conductive spacer comprises an anisotropic conductive material which is electrified vertically and insulated horizontally.

21. The dual-type organic EL display of claim 17, wherein the main substrate electrode lines and the sub substrate electrode lines electrically connected to each other are connected to the at least one FPC.

22. A method of manufacturing a dual-type organic EL display comprising:

preparing a main organic EL device by forming main substrate scan lines, a main substrate insulating layer, a main substrate organic layer, and main substrate data lines crossing the main substrate scan lines on a transparent main substrate;

preparing a sub organic EL device by forming sub substrate scan lines, a sub substrate insulating layer, a sub substrate organic layer, and sub substrate data lines crossing the sub substrate scan lines on a transparent sub substrate;

aging the main and sub organic EL devices;

sealing along the periphery of an effective display area to hermetically seal the main and sub organic EL devices so as not to be exposed outside, wherein the sealant comprises a conductive spacer; and

connecting flexible printed cables (FPCs) transmitting a drive signal to at least one of the main and sub substrate scan lines and/or at least one of the main and sub substrate data lines electrically connected to each other by the sealant.

23. The method of claim 22, wherein the conductive spacer is interposed between each of the main and sub substrate scan lines and/or the main and sub substrate data lines, forming the electrical connection there between.

24. The method of claim 22, wherein in the connecting of the FPCs, the electrically connected main and sub substrate scan lines or main and sub substrate data lines are connected to FPCs on one of the main and sub substrates.

25. A dual-type organic electroluminescence (EL) display comprising:

- a main organic EL device with a first light-emitting portion;
- a sub organic EL device with a second light-emitting portion;
- a sealing unit with a conductive spacer in the sealing unit; and
- at least one flexible printed cable (FPC) coupled to the main or sub organic EL device;

wherein the sealing unit hermetically seals the light-emitting portions facing each other, with the conductive spacer providing an electrical connection between the main and sub organic EL devices, and signals from the at least one FPC are provided directly to one of the devices, and through the conductive spacer to the remaining device.

26. A dual-type organic electroluminescence (EL) display comprising:

- a main organic EL device with a first light-emitting portion;
- a sub organic EL device with a second light-emitting portion;

- electrode lines formed on each of the EL devices;
- floating electrode lines formed on the main or sub EL device;
- a sealing unit; and
- at least one flexible printed cable (FPC) coupled to the main or sub organic EL device;

wherein the floating electrode lines send signals received from the at least one FPC to a plurality of the electrode lines on the device not having the floating electrode lines.

27. The dual-type organic EL display of claim 26, further comprising a conductive spacer in the sealing unit, wherein a plurality of the electrode lines of each device are electrically connected to each other through the conductive spacer.

28. The dual-type organic EL display of claim 27, wherein the electrically connected electrode lines of one of the devices receives signals from the at least one FPC coupled to the other device.

* * * * *

专利名称(译)	双型有机电致发光显示器及其制造方法		
公开(公告)号	US20040056587A1	公开(公告)日	2004-03-25
申请号	US10/665044	申请日	2003-09-22
[标]申请(专利权)人(译)	三星NEC移动显示器		
申请(专利权)人(译)	三星NEC移动显示器有限公司.		
当前申请(专利权)人(译)	三星DISPLAY CO. , LTD.		
[标]发明人	KIM TAE SEUNG		
发明人	KIM, TAE SEUNG		
IPC分类号	H05B33/10 G09F9/00 G09F9/40 H01L27/32 H01L51/00 H01L51/40 H01L51/50 H01L51/56 H05B33/00 H05B33/14 H05B33/26		
CPC分类号	H01L25/048 H01L27/3286 H01L27/3288 H01L51/0024 H01L51/5246 H05K2201/10446 H01L2924/0002 H01L51/56 H05K1/189 H05K2201/10128 H01L2924/00		
优先权	1020020057389 2002-09-19 KR		
其他公开文献	US7034452		
外部链接	Espacenet USPTO		

摘要(译)

一种双型有机EL显示器，包括：主有机EL器件，包括主基板，条形主基板扫描线，主基板有机发光部分和形成在主基板上的主基板数据线；与有机EL器件相对并且面对主有机EL器件的子有机EL器件，包括子基板，条形子基板扫描线，子基板有机发光部分和形成在子基板上的子基板数据线；密封剂包括导电垫片，密封主基板和副基板，并在主有源EL器件和子有机EL器件彼此面对的状态下气密密封主基板和副基板有机发光部分；至少一个柔性印刷电缆（FPC）形成在主基板或副基板上并连接到主基板和/或副基板的电极线。

